

Hamilton Beach[®]

COMMERCIAL

GLOBAL FOODSERVICE EQUIPMENT CATALOG





Over 115 years of commercial expertise
 Since 1911, businesses have relied on Hamilton Beach Commercial® for top-performing, durable equipment. From innovative, high-performance blenders to vacuum packaging machines, we have everything you need to keep your business running smoothly, whether you operate a single restaurant, bar, or manage a chain.
 Hamilton Beach Commercial® has a proud history of designing products with the end user in mind, focusing on quality, durability, and innovation. Another key to our customer-centric process is to support you with exceptional service every step of the way. Think of Hamilton Beach Commercial® as partners in your business — we go out of our way to ensure your satisfaction.

Beverage Prep

2 - 3	Bar Blenders
4 - 5	High-Performance Blenders
6	Beverage Automation
7	Cleaning Solutions
8 - 9	Drink Mixers
10 - 11	Coffee Urns

Food Prep

12 - 13	Expeditor™ Culinary Blenders
14 - 15	Back-of-the-House Equipment
16 - 17	BigRig™ Immersion Blenders
18 - 19	FreshMark™ Juicers
20 - 22	PrimaVac™ Vacuum Packaging
23	Panini and Waffle

Accessories

24 - 27	Accessories and Parts
---------	-----------------------

Bar Blenders

Powering the front of the house

Most bar blenders are pushed to their limit on a daily basis, so they need to be extremely durable and easy to use. These blending workhorses are built to last and can keep up with the demands of the busiest bars. All models feature intuitive controls, so bartenders can focus on blending and serving customers instead of wasting time on complicated functions.

HBB908R Series



HBB908R (120 V)

HBB908R (230 V)

908® Blender

1 peak* HP motor

Blend Drinks in 25 Seconds – Perfect for operations that serve 1-25 drinks daily.

Wave~Action® System – Unique container design continually forces mixture down into blades for a super-creamy drink profile every time.

Two Speeds – For easy control.

4 Durable Stainless Steel Blades – Made to last and get the job done fast.

44 oz./1.3 L Container – Break-resistant polycarbonate container with easy-to-read measurement marks.

Sure Grip™ Feet – Hold blender securely in place.

Lid Open Sensor – Prevents blending with lid removed (230 V only).

HBB255 Series



HBB255 (120 V)

HBB255 (230 V)

Rio® Blender

1.6 peak* HP motor

Blend Drinks in 15 Seconds – Perfect for operations that serve 15-40 drinks daily.

Wave~Action® System – Unique container design continually forces mixture down into blades for a super-creamy drink profile every time.

Optimized Performance – Wide square jar accommodates larger ingredients, reducing prep time.

High Performance Stainless Steel Blades – Quickly cut through ice.

Two Speeds with Pulse Option – Offers versatility and precision blending for a wide variety of drinks.

Lid Open and Jar Pad Sensor – Prevents blending if jar or lid is not on correctly (230 V only).

48 oz./1.4 L Container – Break-resistant BPA-free co-polyester container.

HBB255S Series



HBB255S (120 V)

HBB255S (230 V)

Rio® Blender

1.6 peak* HP motor

Blend Drinks in 15 Seconds – Perfect for operations that serve 15-40 drinks daily.

Wave~Action® System – Unique container design continually forces mixture down into blades for a super-creamy drink profile every time.

Optimized Performance – Wide square jar accommodates larger ingredients, reducing prep time.

High Performance Stainless Steel Blades – Quickly cut through ice.

Two Speeds with Pulse Option – Offers versatility and precision blending for a wide variety of drinks.

Lid Open and Jar Pad Sensor – Prevents blending if jar or lid is not on correctly (230 V only).

32 oz./0.95 L Stainless Steel Container – Built for long-lasting performance.

ACCESSORIZE

Keep your blenders in top condition and your business running smoothly



6126-908RR 44 oz./1.3 L Polycarbonate Container

For HBB908R Series



6126-455 48 oz./1.4 L BPA-Free Co-Polyester Container

For HBB255, HBH455 and HBF510 Series (120 V)



6126-455-CE 48 oz./1.4 L BPA-Free Co-Polyester Container

For HBB255, HBH455 and HBF510 Series (230 V)



98455 Cutter Assembly Jar Repair Kit

For HBB255, HBB255S, HBH455 and HBF510 Series

Turn to page 25 for our complete selection of Bar Blender accessories



HBB908R Ship Weight (120 V and 230 V):

8.1 lbs/3.68 kg

Warranty: 1 year parts & labor

120 V Specifications:

HBB908R
120 V~, 60 HZ, 6 A



230 V Specifications:

HBB908R-CE
HBB908R-UK
220-240 V~, 50-60 HZ, 3 A



HBB255 (120 V) Ship Weight: 9.5 lbs/4.3 kg

HBB255 (230 V) Ship Weight: 4.5 kg/9.92 lbs

Warranty: 2 years parts & labor

120 V Specifications:

HBB255
120 V~, 60 HZ, 6.5 A



230 V Specifications:

HBB255-CE
HBB255-UK
HBB255-CN
220-240 V~, 50-60 HZ, 3.2 A



HBB255S (120 V) Ship Weight: 9.5 lbs/4.3 kg

HBB255S (230 V) Ship Weight: 4.7 kg/10.4 lbs

Warranty: 2 years parts & labor

120 V Specifications:

HBB255S
120 V~, 60 HZ, 6.5 A



230 V Specifications:

HBB255S-CE
HBB255S-UK
HBB255S-CN
220-240 V~, 50-60 HZ, 3.2 A



* Input power

* Input power

High-Performance Blenders

Improving high-volume efficiency

With our high-performance blenders, it's easy to achieve optimum results every time you blend. From convenient timers with automatic shutoff to advanced one-touch cycles, they have everything you need for maximum blending control and efficiency. To reduce noise, consider one with a sound enclosure — it will provide amazing power, yet it won't interrupt conversations.

HBH455 Series



HBH455 (120 V) HBH455 (230 V)

Tango® Blender

2.4 peak* HP motor

Two Speeds and Pulse – Offers versatility and precision blending for a wide variety of drinks.

Wave~Action® System – Unique container design continually forces mixture down into blades for a super creamy drink profile every time.

Timer with Automatic Shutoff – Indispensable for busy bars, it frees operators up for other tasks.

48 oz./1.4 L Stackable Container – BPA-free co-polyester container minimizes storage.

Lid Open and Jar Pad Sensor – Prevents blending if jar or lid is not on correctly (230 V only).

HBH550R Series



Fury™ Blender

3 HP motor

Two Speeds plus Pulse – Offer precision blending for a wide variety of drink mixtures.

Timer with Automatic Shutoff – Indispensable for busy bars, it frees operators up for other tasks.

Powerful 3 HP motor – Built with a durable all-metal drive coupling to satisfy the demands of the busiest bars.

64 oz./1.8 L Stackable BPA-Free Copolyester Container – Features Wave~Action® system for optimal blending performance.

HBH650R Series



Tempest® Blender

3 HP motor

Two Speeds, Jump Cycle, and Pulse Button – Offer precision blending for a wide variety of drink mixtures.

Timer with Automatic Shutoff – Indispensable for busy bars, it frees operators up for other tasks.

Powerful 3 HP motor – Built with a durable all-metal drive coupling to satisfy the demands of the busiest bars.

64 oz./1.8 L Stackable BPA-Free Copolyester Container – Features Wave~Action® system for optimal blending performance.

HBH755R Series



Eclipse™ Blender

3 peak* HP motor

QuietBlend™ Technology – Reduces motor noise and works with the Quiet Shield™ enclosure to lower sound to a conversation level.

Over 100 Pre-programmed Cycles – Can be assigned to 5 buttons for popular drinks and additional cycles can be loaded via USB.

Sensors – Equipped on the shield and jar pad to extend life and ensure quiet operation.

Powerful 3 Peak* HP Motor with Airflow Design – Provides excellent blending results, helps prevent motor overheating, and extends motor life.

64 oz./2 L Stackable BPA-Free Copolyester Container – Features Wave~Action® system for optimal blending performance.

HBH855 Series



Summit® Edge Blender

3.5 peak* HP motor

PowerBlend Technology – Delivers fast, consistent results for even the toughest recipes.

Advanced Quiet Blend™ technology – For ultra-quiet blending.

Auto Blend – For one touch blending.

Intuitive Capacitive Touchpad – With 6 programmable buttons, variable speeds and pulse.

36 Pre-Programmed Cycles in 11 Languages – Easily accessible USB port for uploading additional custom cycles.

Powerful 3.5 peak* HP motor – With hybrid drive coupling delivers ample power and torque to stainless steel blades.

Stackable 48 oz./1.4 L BPA-free copolyester container

ACCESSORIZE

6126-751R AirWhip Frothing Jar

Quickly creates perfect milk foam and emulsifies dressings and sauces



Cold foam in less than 20 seconds

- Versatile 48 oz./1.4 L container for delicate blends
- Removable filler cap
- Durable jar clutch

6126-855R Blender Container



- Fits HBH855 Series
- Stackable 48 oz./1.4L BPA-free copolyester container
- Stainless steel blade
- Laser-etched measurements

Turn to page 24-26 for our complete selection of High Performance Blender jars and accessories

HBH455 (120 V) Ship Weight: 11.9 lbs/5.4 kg
HBH455 (230 V) Ship Weight: 5.6 kg/12.3 lbs
Warranty: 2 years parts & labor

120 V Specifications:
 HBH455
 120 V~, 60 HZ, 10 A

230 V Specifications:
 HBH455-CE
 HBH455-UK
 HBH455-CN
 220-240 V~, 50-60 HZ, 6.5 A

* Input power

Ship Weight: 15.21 lbs/6.9 kg
Warranty: 3 years parts & labor (lifetime on motor drive coupling and blade)

120 V Specifications:
 HBH550R
 120 V~, 60 HZ, 12.5 A

230 V Specifications:
 HBH550R-CE
 HBH550R-UK
 HBH550R-CCC
 220-240 V~, 50-60 HZ, 1200 W

RoHS COMPLIANT

Ship Weight: 15.01 lbs/6.81 kg
Warranty: 3 years parts & labor (lifetime on motor drive coupling and blade)

120 V Specifications:
 HBH650R
 120 V~, 60 HZ, 12.5 A

230 V Specifications:
 HBH650R-CE
 HBH650R-UK
 HBH650R-CCC
 220-240V~, 50-60 HZ, 1200 W

RoHS COMPLIANT

Ship Weight: 21.7 lbs/9.8 kg
Warranty: 3 years parts & labor (lifetime on motor drive coupling and blade)

120 V Specifications:
 HBH755R
 120 V~, 60 HZ, 12 A

230 V Specifications:
 HBH755R-CE
 HBH755R-UK
 HBH755R-CN
 220-240 V~, 50-60 HZ, 7.8 A

RoHS COMPLIANT

* Input power

Ship Weight: 32 lbs/14.5 kg
Warranty: 3 years parts & labor (lifetime on blade)

120 V Specifications:
 HBH855
 120 V~, 60 HZ, 13.5 A

230 V Specifications:
 HBH855-CE
 HBH855-UK
 HBH855-CN
 220-240 V~, 50-60 HZ, 7.5 A

RoHS COMPLIANT

Beverage Automation

Taking automation to the next level

Cleaning Solutions

HBS1400R Series



Revolution® Ice Shaver/Blender

5 gallon / 19 L ice capacity

Revolution® Portion System – For maximum accuracy, the ice portioning system counts the number of times the agitator passes the shaver blade. Regardless of the motor load, the correct amount of ice comes out every time.

Double-Wall Hopper – Insulated for quiet operation and to keep ice cold.

Sensor Technology – Hopper sensor prevents operation when lid is not in place. Drain sensor indicates if water is backed up in the drain.

Powerful 3 HP Motor – Heavy-duty and built to satisfy the demands of the busiest bars.

Automatic Cycle Buttons – Lets operators select serving size and number of servings for precise results.

64 oz./1.8 L Stackable Container with Wave-Action® System – Provides optimal blend performance.



Ship Weight: 71 lbs/32.2 kg

Warranty: 2 years parts & labor (lifetime on motor drive coupling and blade)

120 V Specifications

HBS1400R
120 V~, 60 HZ, 15 A



230 V Specifications:

HBS1400R-CE
220-240 V~, 50-60 HZ, 1000 W



Comes with CE and UK cordsets

RoHS COMPLIANT

BIC3000T Series



SmartServe™

Blends in the cup

Mixes Milk Shakes or Incorporates Mix-Ins – Makes it easy for customers or crew members to mix treats.

Simple, Clean Process – Just add ingredients to cup, insert cup in machine, and press start.

It blends and stops automatically and the drink is ready to serve.

Rotating Cup Holder – Automatically rotates cup as it mixes for evenly mixed treats.

Saves Water – Rinses with as little as 10 oz./300ml of water. It reduces water usage by 8 times compared to manual cleaning.

Increases Productivity – Staff can perform other tasks while the machine blends.



Ship Weight: 105 lbs/48 kg

Warranty: 1 year parts & labor

120 V Specifications:

BIC300T
120 V~, 60 HZ, 6.2 A



BCR100R

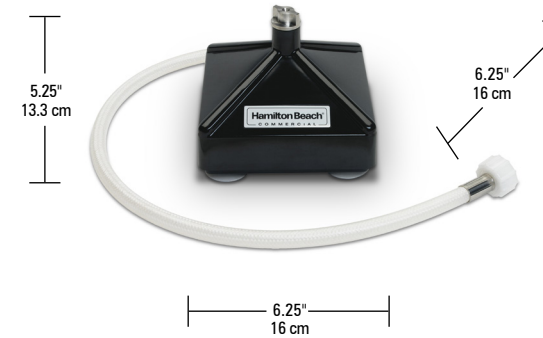

Container Rinser

Designed To Rinse Various Containers – Rinses all jars, cups and containers up to 64 oz./2 L.

Durable Construction – Stainless steel spray nozzle; break-resistant polycarbonate.

Easy Operation – A gentle push on platform activates spray.

Compact and Low Profile Design – Fits easily in sink at 6.25"/160 mm square and 5.25"/133 mm high.

Raised Nozzle – For better cleaning.

Suction Cup Feet – Hold rinser securely in place.



Ship Weight: 1.2 lbs/0.5 kg

Warranty: 1 year parts & labor

BCR100R Specifications:

Unit comes with base, nozzle, hose. Base: break-resistant polycarbonate; with 4 suction cups. 2.5 ft./0.7 m flexible 3/8" / 10 mm (ID) reinforced tubing with swivel garden hose (GHT) fitting. No electricity required. Flow rate: 2.25 gpm/8.521 pm@60 psi



BCR200



For Use with BCR100R Rinser (Not Included)

Container Rinser Station

Basin – Allows BCR100R Rinser to drain directly back into the sink with no mess.

Removable Drain Grate – Prevents clogged lines.

Accessory Rinsing Attachment – Rinse containers, lids mugs and cups with ease just by pressing down.

Nonslip Suction Feet

Water Supply Bushing – Holds BCR100R water supply hose in place.

Ship Weight: 3.5 lbs/1.6 kg

BCR200 Specifications:

Unit comes basin, drain grate, water supply bushing and accessory rinsing attachment. No electricity required.



Drink Mixers

Mixing perfect shakes since 1911

We invented the first drink mixer over 100 years ago, and we're still going strong today with our wide selection of world-class mixing machines. From timeless drink mixers to heavy-duty mixing machines, you'll get all the mixing control and power you need, whether you're preparing creamy milk shakes with hard ice cream or soft-serve creations with candy mix-ins.

HMD200R Series



Single Spindle Mixes one shake

Versatile Drink and Food Prep – Great for everything from mixing shakes and “flashing” bar drinks to blending eggs and batters.

Excellent Mixing Performance – Powerful 1/3 HP precision motor is balanced to minimize vibration and is built to last with sealed, permanently lubricated ball bearings. Operator can easily replace motor in minutes.

Two-Way Motor Activation – Operators can start and stop mixing action by inserting the cup into the cup guide or by using the pulse switch on the top of the mixer.

Easy to Clean – Smooth housing made of stainless steel and die-cast aluminum. Cup guide removes for cleaning.

Sealed Housing – Eliminates the risk of water ingress and motor failure.

Global Care ExpressCare U.S. ONLY

Ship Weight: 15.4 lbs/7.0 kg
Warranty: 1 year parts & labor

120 V Specifications:
HMD200R
120 V~, 60 HZ, 300 W

230 V Specifications:
HMD200R-CE
HMD200R-UK
HMD200R-CN
220-240 V~, 50-60 HZ, 300 W

ETL Intertek NSF NOM CE CCC RoHS COMPLIANT

HMD300R Series



Wall Mount Saves space

Saves Valuable Counter Space – Fully featured in convenient wall-mount design, and plugs into standard outlet.

Excellent Mixing Performance – Powerful 1/3 HP precision motor is balanced to minimize vibration and is built to last with sealed, permanently lubricated ball bearings. Operator can easily replace motor in minutes.

Two-Way Motor Activation – Operators can start and stop mixing action by inserting the cup into the cup guide or by using the pulse switch on the top of the mixer (120 V only).

Easy to Clean – Smooth housing made of stainless steel and die-cast aluminum.

Sealed Housing – Eliminates the risk of water ingress and motor failure.

Global Care ExpressCare U.S. ONLY

Ship Weight: 10.5 lbs/4.8 kg
Warranty: 1 year parts & labor

120 V Specifications:
HMD300R
120 V~, 60 HZ, 250 W

ETL Intertek NSF NOM CE CCC RoHS COMPLIANT

HMD400R Series



Triple Spindle High-volume applications

Ideal for High Volume – All the features of the single spindle mixer with triple the volume.

Excellent Performance – Powerful 1/3 HP motor for each spindle, each with its own controls.

Precision Motor – Balanced to minimize vibration and built to last with sealed, permanently lubricated ball bearings.

Two-Way Motor Activation – Operators can start and stop mixing action by inserting the cup into the cup guide or by using the pulse switch on the top of the mixer.

Easy to Clean – Smooth housing made of stainless steel and die-cast aluminum. Cup guide removes for cleaning.

Sealed Housing – Eliminates the risk of water ingress and motor failure.

Global Care ExpressCare U.S. ONLY

Ship Weight: 37.6 lbs/17.1 kg
Warranty: 1 year parts & labor

120 V Specifications:
HMD400R
120 V~, 60 HZ, 900 W

230 V Specifications:
HMD400R-CE
HMD400R-UK
220-240 V~, 50-60 HZ, 900 W

ETL Intertek NSF NOM CE CCC RoHS COMPLIANT

HMD880 Series



MixStation™ Heavy-duty mixing

Brushless Induction Motor – Provides quiet operation and worry-free use.

Single speed operation – Operators can easily start and stop mixing action by flipping the switch.

Wide Working Space – Allows easy maneuvering of cup without restrictions.

Contoured Splash Shield – Reduces discomfort on the operator's wrist.

Easy To Clean – Smooth, rounded corners easily wipe clean. Drip tray and magnetic splash shield are removable.

Optional Foot Pedal – For hands-free power activation (120 V only).

Global Care ExpressCare U.S. ONLY

120 V Ship Weight: 32 lbs/14.5 kg
Warranty: 1 year parts & labor

120 V Specifications:
HMD880
120 V~, 60 HZ, 4.8 A

230 V Specifications:
HMD880-CE
220-240 V~, 50-60 HZ, 5.4 A

ETL Intertek NSF NOM CE CCC RoHS COMPLIANT

HMD1000 Series



MixStation™ Heavy-duty mixing with more control

Powerful Mixing Performance – 3/4 HP motor provides heavy-duty mixing action for ice cream treats with candy, fruit, and nut mix-ins.

Pre-programmed Cycles – Deliver consistent results regardless of the operator with option to upload custom programs via USB

Variable Speed Dial – Provides maximum flexibility and customization.

Capacitive Touch Controls – Sealed for easy cleaning.

Contoured Splash Shield – Reduces discomfort on the operator's wrist.

Easy To Clean – Smooth, rounded corners easily wipe clean. Drip tray and magnetic splash shield are removable.

Optional Foot Pedal – or hands-free power activation (120 V only).

Global Care ExpressCare U.S. ONLY

120 V Ship Weight: 27 lbs/12.2 kg
Warranty: 1 year parts & labor

120 V Specifications:
HMD1000
120 V~, 60 HZ, 6.0 A

230 V Specifications:
HMD1000-CE
HMD1000-UK
HMD1000-CN
220-240 V~, 50-60 HZ, 6.5 A

ETL Intertek NSF NOM CE CCC RoHS COMPLIANT

ACCESSORIZE

HMD300MR Series Machine-Mount Drink Mixer

Specially designed to attach to soft-serve ice cream machines to add drink-making flexibility to your operation



110E Stainless Steel Cup

Holds 32 oz. (.95L) and is compatible with all drink mixers



928 Agitator

Compatible with all HBC drink mixers



929 Agitator

Compatible with all HBC drink mixers



Turn to page 26 for our complete selection of Drink Mixer accessories

Coffee Urns

Serving coffee for a crowd

Meet all your hospitality needs. From large groups at hotels and conventions to catering applications, churches or other gatherings, our comprehensive selection of commercial coffee urns meets every need. Every coffee urn is exceptionally easy to use and clean, and the stainless steel models offer removable tanks for even easier filling and cleaning. No matter what size crowd or budget you have, you'll find one that's just right for you.

HCU040S



40 Cup Coffee Urn

Brews 1 Cup Per Minute

One Hand Dispensing – Fills cups fast for superior service.

Double-Wall, Insulated Tank – Reduces risks of hand burns by keeping outside cooler.

Dual Heaters and Indicator Lights – Brew and gentle warm.

Convenient Locking Lid – A quick twist locks lid in place.

Removable Stainless Steel Brew Basket

Embossed Level Marks Inside Urn – For exact measurement of coffee.

Boil Dry Protection – Shuts off when empty

Easy Lift Handles



Ship Weight: 11.5 lbs/5.2 kg
Warranty: 1 year parts & labor

120 V Specifications:
HCU040S
120 V~, 60 HZ, 1440 W



HCU075S



75 Cup Coffee Urn

Brews 1 Cup Per Minute

One Hand Dispensing – Fills cups fast for superior service.

Double-Wall, Insulated Tank – Reduces risks of hand burns by keeping outside cooler.

Dual Heaters and Indicator Lights – Brew and gentle warm.

Convenient Locking Lid – A quick twist locks lid in place.

Removable Stainless Steel Brew Basket

Embossed Level Marks Inside Urn – For exact measurement of coffee.

Boil Dry Protection – Shuts off when empty

Easy Lift Handles



Ship Weight: 14 lbs/6.4 kg
Warranty: 1 year parts & labor

120 V Specifications:
HCU075S
120 V~, 60 HZ, 1440 W



HCU100S



100 Cup Coffee Urn

Brews 2 Cups Per Minute

One Hand Dispensing – Fills cups fast for superior service.

Double-Wall, Insulated Tank – Reduces risks of hand burns by keeping outside cooler.

Dual Heaters and Indicator Lights – Brew and gentle warm.

Convenient Locking Lid – A quick twist locks lid in place.

Removable Stainless Steel Brew Basket

Embossed Level Marks Inside Urn – For exact measurement of coffee.

Boil Dry Protection – Shuts off when empty

Easy Lift Handles



Ship Weight: 15 lbs/6.8 kg
Warranty: 1 year parts & labor

120 V Specifications:
HCU100S
120 V~, 60 HZ, 1440 W



D50065



Coffee Urn

60 Cup Capacity

One-Hand Dispensing – Fills cups fast with one hand to shorten the wait.

Classic Polished Stainless Steel Exterior – For long-lasting performance.

Keep Warm Heater – Maintains coffee's optimal temperature for fresh flavor with less bitterness.

Water/Coffee Window – Makes filling easy and shows you at a glance when coffee level is low.

Ready Light – Shows you when brew cycle is complete.

Stainless Steel Interior – Resists stains and buildup for easy cleaning.

Glass Knob On Lid – Lets you view the brewing cycle.



120 V Ship Weight: 11.5 lbs/5.21 kg
Warranty: 1 year parts & labor

Specifications:
D50065
120 V~, 60 HZ, 1000 W



EXPEDITOR™ Family of Culinary Blenders

Creating the perfect blend for chefs

Ordinary blenders can't compete with Expeditor™ blenders when it comes to culinary output and precision. From blending soups and sauces to emulsifying marinades and dressings, these culinary blenders help talented chefs around the world express their artistic vision. Even better, their intelligent controls and large capacities maximize speed-to-table so you can uphold impeccable service.

HBF510 Series



HBF510 (120 V) | HBF510 (230 V)

HBF510S Series



HBF510S (120 V) | HBF510S (230 V)

48 oz./1.4 L BPA Free Co-Polyester Container

Variable Speed & Pulse Functions –

Allow for easier blending, pureeing, grinding, chopping, and emulsifying.

Chop Function – Cycles between low speed and operator-selected high speed.

2.4 Peak HP* Motor – Has the torque needed for blending ingredients.

Sealed Paddle Switches – Leak resistant and easy to use.

Durable Metal Drive Coupling

Large Dosing Cup – Makes it easier to add liquid for emulsions while blending.

Stainless Steel Blades – Quickly cut through every ingredient.

Lid Open Sensor – prevents blending when lid is removed (230 V only).

64 oz./1.8 L Container

Variable Speed & Pulse Functions – Blending, pureeing, grinding, chopping, and emulsifying.

Chop Function – Cycles between low speed and operator-selected high speed.

2.4 Peak HP* Motor – Has the torque needed for chopping ingredients.

Stainless Steel Container – Provides durability and has an easy-grip handle.

Durable Metal Drive Coupling

Large Dosing Cup – Makes it easier to add liquid for emulsions while blending.

Stainless Steel Blades – Quickly cut through every ingredient.

Sealed Paddle Switches – Leak resistant and easy to use.

Lid Open Sensor – prevents blending when lid is removed (230 V only).

HBF600R Series



HBF600R

64 oz./1.8 L Container

Variable Speed & Pulse Functions –

Allow for easier blending, pureeing, grinding, chopping, and emulsifying.

One-Touch Chop Function – Cycles between low speed and operator-selected high speed.

3 HP Motor – Provides the torque needed for effectively blending ingredients.

Wave~Action® Container – Keeps contents circulating through blades to ensure that contents are consistently incorporated.

Large Dosing Cup – Makes it easier to add liquid for emulsions while blending.

Temperature Gauge – Alerts operator if motor overheats while blending back-to-back batches.

HBF900SR Series



HBF900SR

1 gallon/4 L Container

Heavy-Duty Construction – Built for long-lasting performance in the world's busiest kitchens.

Saves Prep Time – With its powerful 3.5 HP motor and 1 gallon (4 L) container, this blender is fully equipped to produce great results in a fraction of the time.

Low-Profile Design – Offers convenient access to container on any kitchen countertop. Also makes it easy to move the blender from one kitchen location to another.

Easy-to-Use Controls – 3 speeds plus pulse provide precision every time.

Lid Interlock – Ensures the blender won't start until the jar and lid are securely in place.

Transparent Lid and Dosing Cup – Gives operators a clear view while blending.

HBF1100SR Series



HBF1100SR

1 gallon/4 L Container

Saves Prep Time – Powerful 3.5 HP motor and large container help you finish blending jobs faster.

Low-Profile Design – For convenient access to the container on any countertop.

Unique Chop Function – Provides improved blending performance.

Custom Program Buttons – Offer a large degree of custom blending and precision control.

Variable Speed Dial – Allows blending from a very low speed to a high speed that quickly creates a smooth puree.

Preset Timer Buttons – Gives operators more time to perform other kitchen tasks.

Lid Interlock – Ensures that the blender won't start until the jar and lid are securely in place.



Ship Weight: 12.3 lbs/5.6 kg

Warranty: 2 years parts & labor

120 V Specifications:

HBF510
120 V~, 60 HZ, 10 A



230 V Specifications:

HBF510-CE
HBF510-UK
220-240 V~, 50-60 HZ, 6.5 A



Ship Weight: 13.9 lbs/6.3 kg

Warranty: 2 years parts & labor

120 V Specifications:

HBF510S
120 V~, 60 HZ, 6.5 A



230 V Specifications:

HBF510S-CE/UK
HBF510S-CN
220-240 V~, 50-60 HZ, 6.5 A

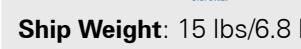

Ship Weight: 15 lbs/6.8 kg

Warranty: 3 years parts & labor (lifetime on motor drive coupling and blade)

120 V Specifications:

HBF600R
120 V~, 60 HZ, 12.5 A



230 V Specifications:

HBF600R-CE
220-240 V~, 50-60 HZ, 1200 W
European and UK cordset included



Ship Weight: 24.3 lbs/11 kg

Warranty: 3 years parts & labor (lifetime on motor drive coupling and blade)

120 V Specifications:

HBF900SR
120 V~, 60 HZ, 14 A



230 V Specifications:

HBF1100SR-CE
HBF1100SR-UK
HBF1100SR-CN
220-240 V~, 50-60 HZ, 1500 W



Back-of-the-House Equipment

Providing versatility and durability

By saving valuable time and labor, these versatile kitchen tools can help every commercial food operation improve their bottom line. From small shops to large restaurants, our hard-working tools are the ones to keep on hand when you need to mix cookie doughs or cake batters, prepare perfect rice, open cans, or serve food with consistent portion sizes.

CPM800 Series

37590

HCO500

78 Series

80 Series



Stand Mixer

Powerful performance

8 Quart (8 L) Capacity – Small enough for the countertop, yet robust enough to handle any mixing job.

Tilt-Back Head – Makes it easy to add ingredients, scrape sides, change attachments, and remove the bowl.

Stainless Steel Bowl with Handles – Makes it easy to lift and carry contents.

Heavy-Duty Attachments – Stainless steel beater, dough hook & wire whisk with splash shields to keep ingredients away from the hub area.

Variable 7 Speed Dial + Pulse – Allows for speed changes while mixing.

Sealed Stop/Start Buttons – Easily respond to touch for ease of use.



Rice Cooker

90 Cup/21 L

Extra-Large Capacity – Lets you cook 90 cups of cooked rice (45 cups raw).

Digital Control Panel – Provides multiple cooking options and is easy to keep clean.

Heat/Simmer Function – Maintains the right temperature to help prevent boilover for up to 4 hours.

Insulated Double-Wall Construction – With hinged/heated lid that's easy to open and close.

Nonstick Inner Pot with Handles – Makes it easy to lift and carry contents.

Condensation Cup – Collects water to keep messy drips off countertops.

Accessories Included – Rice measuring cup and paddle.



Side-Cut Can Opener

No more sharp edges

Opens Seam of Can – Cans are opened on the side seam instead of puncturing the lid, so no sharp edges.

No Cross Contamination – No blade to make contact with food, unlike conventional can openers.

No Risk of Metal Shavings – Since the lid is not being cut with a blade, metal shavings won't get into the food.

No Gears to Wear or Break – Removes the possibility of downtime.

Durable Construction – Made of stainless steel and nickel-plated aluminum for durable performance.

Same Mounting Pattern as Edlund* – for easy installation.



78 Series Dishers

Classic style

Portion Control – Each of the 9 disher sizes lets you serve consistent portions every time. Choose from the smallest purple disher with 1-1/2" bowl diameter to the largest white disher with 3" bowl diameter.

Color-Coded Handles – Bright, identifiable colors make it easy to select the correct disher for improved service and correct portion sizes.

Durable Stainless Steel – The bowl, thumb lever, and spring are made of stainless steel for long life and easy cleanup in the dishwasher.

Heavy-Duty Spring Action – The heavy-duty stainless steel spring allows for ease of operation and long-lasting durability.



80 Series Dishers

Deluxe style

80 series dishers have all the features of the 78 series shown left, plus these extras:

Pan Rest™ Feature – These convenient notches in the handles let the dishers rest on the edge of pans to help prevent slippage that could slow down service.

Ergonomic Grip – Handles are shaped to create a comfortable grip, which helps reduce hand and arm fatigue.

Imprinted Capacity – Since the capacity of each disher is clearly molded onto the handle, there's never a question about which size disher is being used.



Global Care Express Care U.S. ONLY

Ship Weight: 35.8 lbs/16.3 kg

Warranty: 2 years parts & labor

120 V Specifications: CPM800 120 V~, 60 HZ, 800 W/ 7A

230 V Specifications: CPM800-CE CPM800-UK CPM800-CN 220-240 V~, 50-60 HZ, 1500 W, IPX2

ETL NSF NOM CE RoHS COMPLIANT

Global Care Express Care U.S. ONLY

Ship Weight: 38.9 lbs/17.6 kg

Warranty: 1 year parts & labor

240 V Specifications: 37590 240 V~, 60 HZ, 2500 W NEMA 6-15P type plug

ETL NSF Conforms to NSF/ANSI Std. 8 6-15P

Global Care

Ship Weight: 5.1 lbs/2.3 kg

Warranty: 1 year parts & labor

NSF

* Edlund is the trademark of Edlund Company, Inc. Use of the mark does not suggest any affiliation or endorsement by Edlund Company.

Global Care NSF **Ship Weight:** Varies depending on size **Warranty:** 1 year parts & labor (78 series) 2 years parts & labor (80 series)

Model	Color	Disher Size		Capacity		
		Servings/ Quart	Bowl Dia. Inches	ML*	FL OZ**	Cup/Tbsp.
78/80-06	White	6	3"	138	4¾	½ Cup
78/80-08	Grey	8	2¾"	108	3¾	½ Cup
78/80-10	Ivory	10	2½"	94	3¼	¾ Cup
78/80-12	Green	12	2½"	82	2¾	¾ Cup
78/80-16	Blue	16	2¼"	61	2	¼ Cup
78/80-20	Yellow	20	2½"	52	1¾	3½ Tbsp.
78/80-24	Red	24	2"	44	1½	3 Tbsp.
78/80-30	Black	30	1¾"	30	1"	2¼ Tbsp.
78/80-40	Orchid	40	1½"	20	¾	1½ Tbsp.

* Water capacity ** Approximate

Immersion Equipment

The dependable workhorses of your foodservice kitchen

Built for chefs and foodservice professionals, the BigRig™ family of immersion blenders create large batches without sacrificing time or quality. With power to spare, they quickly power through every high volume blending, chopping, and emulsifying job. ThumbDrive® color-coded speed dials and ergonomic handles guarantee operators' comfort and convenience.

HMI Series of Immersion Blenders

BigRig™

BigRig™ Family of Immersion Blenders

Stainless Steel Shaft with Ergonomic Grip – Detaches to let you change to a different-size shaft.

ThumbDrive™ Variable Speed Dial – With color-coded light for immediate feedback about blender status.

Continuous Run Operation for High-Volume Blending

Stainless Steel Blade with Guard – Blends, chops, purees, or emulsifies ingredients quickly.

Ergonomic Design with Light-Touch Controls – Offers multiple hand positions.

Wall Mount and Cord Holder – For neat, easy storage.

Serviceable 12 ft./365cm Power Cord Designed for High Visibility

* 800 watts for 120 V; 1000 watts for 220-240 V



Warranty: 2 years parts and labor

Ship Weights:

HMI012	HMI014	HMI016	HMI018	HMI021	HMI02W
14.5 lbs	14.7 lbs	15 lbs	15.3 lbs	15.8 lbs	6.0 lbs
6.6 kg	6.7 kg	6.8 kg	6.9 kg	7.2 kg	2.7 kg

HMI (120 V) Specifications:
120 V~, 60 HZ, 800 W



HMI (230 V) Specifications:

-CE
-UK
-CN
220-240 V~, 50-60 HZ, 1000 W, IPX1

RoHS COMPLIANT



Interchangeable Shaft Sizes Available (sold separately)



HMS12 12"/305mm
HMS14 14"/355mm
HMS16 16"/406mm
HMS18 18"/457mm
HMS21 21"/533mm

HMI009 Series

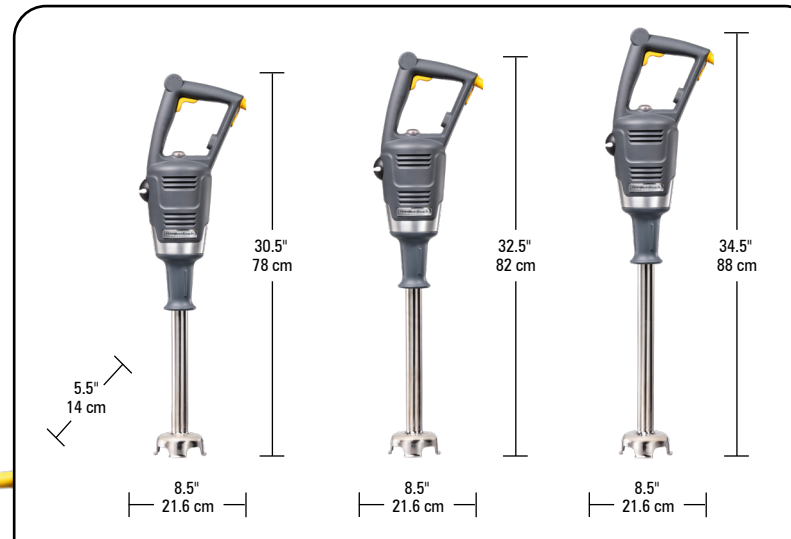

HMI012

HMI014

HMI016

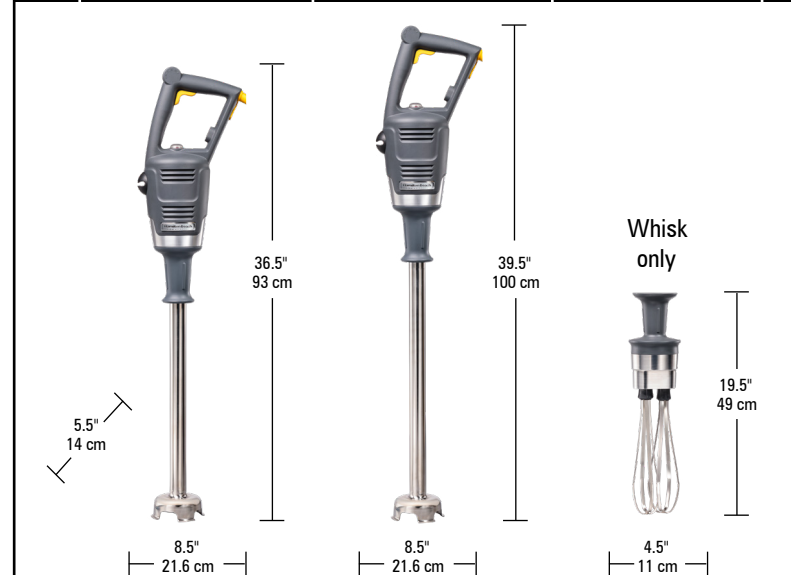

HMI018

HMI021

HMI02W

Blend Volume Chart

12"/305mm shaft - up to 6 gal. (23 L)
14"/355mm shaft - up to 14 gal. (53 L)
16"/406mm shaft - up to 23 gal. (87 L)
18"/457mm shaft - up to 32 gal. (121 L)
21"/533mm shaft - up to 42 gal. (158 L)

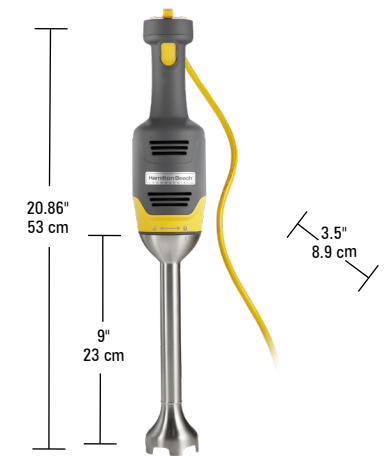

BigRig™ Compact Immersion Blender 9" shaft

9"/23 cm Stainless Steel Shaft – Ideal for smaller food batches up to 3 gallons/11 liters.

Variable Speed Dial – Provides greater control over textures of sauces, purees, soups.

Easy to Use – Provides maximum blending control and comfortable to handle.

High-Visibility 8 ft./2.4m Yellow Power Cord – Helps ensure safety in busy kitchens.



Ship Weight: 6.2 lbs/2.8 kg

Warranty: 2 years parts & labor

120 V Specifications:

HMI009
120 V~, 60 HZ, 250 W



230 V Specifications:

HMI009-AU
HMI009-CE
HMI009-SA
HMI009-UK
HMI009-CN



RoHS COMPLIANT
220-240 V~, 50-60 HZ, 250 W

FreshMark™ Family of Juicers

Maximizing juice output

We've built commercial-quality juicers since 1932, when our 932 manual juicer first made its mark. Today the FreshMark™ family of commercial juicers offers businesses the maximum output they need in order to keep the juice flowing. Whether you run a juice shop, bar, supermarket, or a chain of restaurants, each one is expertly designed to offer you excellent juicing performance you can count on every single day.

932

HCJ967R Series

HWG800

HJE960R Series

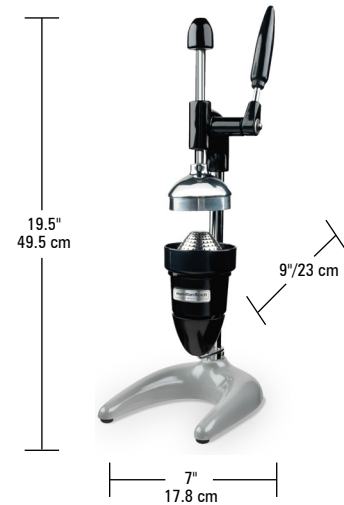

Manual Citrus Juicer

Fills a glass of juice in less than a minute

20-50 Glasses Daily – Ideal for operations that serve up to 50 glasses of juice per day.

Citrus Versatility – Designed to extract juice from lemons, limes, oranges, and grapefruits.

Maximum Juice Extraction – Exerts up to 2000 lbs. of force to ensure maximum juice output.

Acid-Resistant Finish – Resists wear and tear from exposure to citrus acids.

Stainless Steel Strainer Cone – Removes for easy cleaning in the dishwasher.

5.5" Cup Clearance – Provides ample room to place an 8-10 oz. cup underneath for juicing.

Sure Grip™ Feet – Keep the juicer firmly in place.



Electric Citrus Juicer

Fills a glass of juice in less than 30 seconds

100+ Glasses Daily – For operations that serve up to 100 glasses of juice per day.

Citrus Versatility – Designed to extract juice from lemons, limes, oranges, and grapefruits.

Exceptionally Quiet – The brushless induction motor is barely audible, so operators can more easily focus on customers.

Heavy-Duty Construction – Designed to withstand continuous juicing. Die-cast aluminum base makes the juicer less prone to tipping over.

3 Metal-Reinforced Reamers – Maximize juice output from small to large citrus fruits.

Stainless Steel Juice Bowl – Removes for easy cleaning.

Extra-Tall (8.5"/21.6cm) Spout – Accommodates everything from small juice glasses to large pitchers.



Wheatgrass Juicer

Extracts up to 5 oz./150ml per minute

Versatile Extraction – Designed to extract juice from wheatgrass, ginger, and leafy herbs.

Powerful, High-Torque Motor – Provides optimal juice extraction for maximum yield.

Durable Construction – Solidly built for rigorous professional use with stainless steel components and permanently lubricated, air-cooled motor.

Surgical-Grade Internal Assembly – Top-quality 304 surgical grade stainless steel parts provide long life.

Removable Food Zone Parts – Can be quickly removed for fast, easy cleaning.

Convenient Toggle Switch – Includes a reverse option for cleaning after extracting dry herbs and sprouts.

Maintenance Kit Included – Comes with 2 metal screens and two gaskets.



otto™ The Juice Extractor

Extracts approximately 2 qts./2L per minute

100+ Glasses Daily – For operations that require large yields of juice from a variety of produce and/or serve 100 or more glasses of juice per day.

Centrifugal Extraction – Extracts juice from apples, carrots, cucumbers, celery, red beets, ginger, leafy greens, and more.

Powerful Brushless Induction Motor – Provides quiet operation and has dual cooling fans for continuous juicing.

Heavy-Duty Die-Cast Base – Provides exceptional durability and keeps juicer sitting securely on the countertop.

3" (76cm) Feed Chute Opening – Minimizes prep time.

Simple Single-Speed Operation – For effortless juicing.

Top-Quality Parts – Stainless steel and BPA-free parts provide exceptional durability and are easy to clean.

Heavy-Duty Metal Handle – withstands repeated opening and closing and stops motor before lid can be opened.



Ship Weight: 9.4 lbs/4.3 kg

Warranty: 1 year parts & labor



Ship Weight: 30.8 lbs/13.9 kg

Warranty: 2 years parts & labor

120 V Specifications:

HCJ967R
120 V~, 60 HZ, 3 A



230 V Specifications:

HCJ967R-CE
HCJ967R-UK
HCJ967R-CN
220-240 V~, 50-60 HZ, 250 W



Ship Weight: 37 lbs/16.8 kg

Warranty: 1 year parts & labor

120 V Specifications:

HWG800
120 V~, 60 HZ, 375 W



230 V Specifications:

HWG800
220-240 V~, 50-60 HZ, 375 W



Ship Weight: 77 lbs/35 kg

Warranty: 2 years parts & labor

120 V Specifications:

HJE960R
120 V~, 60 HZ, 8.5A



230 V Specifications:

HJE960R-CE
HJE960R-UK
HJE960R-CN (50 mm feed chute)
220-240 V~, 50-60 HZ, 1200 W



PrimaVac™ Family of Vacuum Packaging

Preserving food's freshness and flavor

With PrimaVac™ vacuum packaging machines, commercial kitchens can accomplish a wide variety of tasks, from preserving food's freshness to giving chefs the ability to prep dishes for sous vide.

HVC254 Series



HVC305 Series



HVC406 Series



HSV1000 Series



Packaging Supplies

Equip your kitchen with the vacuum sealer pouches your staff needs for food storage and sous vide applications.

PrimaVac™ In-Chamber Sealer Pouches

- Meets FDA guidelines for temperatures above 121°C (249°F)
- Made of 9 layers of smooth PA and PE for oxygen barrier and puncture protection
- Available in 3 and 4 mil thicknesses

NSF See next page for complete selection of pouches



PrimaVac™ In-Chamber Vacuum Packaging Machines

10" (254mm) seal bar

10 Custom Programs – Let you adjust vacuuming and sealing times for different needs and recipes.

Powerful JetAire™ 8 m3/h Vacuum Pump – Provides robust, long-lasting service.

Adjustable Soft Air – Protects delicate food.

Adjustable Sealing and Cooling Time – Lets you customize sealing action to your exact preference and applications.

Oil Change Reminder – Helps ensure that you maintain a top-functioning pump.

Durable Stainless Steel Housing – Ensures long-lasting beauty and is easy to clean.

Accessories and Power Cords Included – Comes with 80 pouches, filler plate, tools, and electrical cords for UK, Continental Europe, and China.

12" (305mm) seal bar

10 Custom Programs – Let you adjust vacuuming and sealing times for different needs and recipes.

Powerful JetAire™ 12 m3/h (120 V), 10 m3/h (230 V) Vacuum Pump – Provides robust, long-lasting service.

Adjustable Soft Air – Protects delicate food.

Adjustable Sealing and Cooling Time – Lets you customize sealing action to your exact preference and applications.

Oil Change Reminder – Helps ensure that you maintain a top-functioning pump.

Durable Stainless Steel Housing – Ensures long-lasting beauty and is easy to clean.

Accessories and Power Cords Included – Comes with 80 pouches, filler plate, tools, and electrical cords for UK, Continental Europe, and China.

16" (406mm) seal bar

Gas Flush – Creates a protective cushion to keep food from being crushed.

10 Custom Programs – Let you adjust vacuuming and sealing times for different needs and recipes.

Powerful JetAire™ 24 m3/h (120 V), 20 m3/h (230 V) Vacuum Pump – Provides robust, long-lasting service.

Adjustable Soft Air – Protects delicate food.

Adjustable Sealing and Cooling Time – Lets you customize sealing action to your exact preference and applications.

Oil Change Reminder – Helps ensure that you maintain a top-functioning pump.

Accessories and Power Cords Included – Comes with 80 pouches, filler plate, tools, and electrical cords for UK, Continental Europe, and China.

AcuVide™ 1000 Sous Vide Circulator

1200 Watt Water Heater – Keeps up to 8 gallons (30 L) of water at an even, consistent temperature for uniform cooking.

IPX7 Construction – Prevents malfunction if accidentally dropped in water.

Adjustable Timer with Easy-to-Read Display – Select up to 99 hours of sous vide time and set water temperature in your choice of Fahrenheit or Celsius.

Stainless Steel Lower Housing – Removes for easy cleaning.

Cleaning Cycle and Reminder – Helps keep the circulator in top performance.

Water Level Marks and Warning Signal – Help unit run uninterrupted.

Adjustable Clamp – Allows for best placement in vessel and secures without tools.

Global Care

Ship Weight: 80 lbs/36 kg

Warranty: 2 years parts & labor; 3 years with product registration

HVC254 120 V Specifications: 120 V~, 60 HZ, 3 A

HVC254-CE 220 V Specifications: 220-240 V~, 50-60 HZ, 400 W

RoHS COMPLIANT

Global Care

Ship Weight: 94 lbs/42 kg

Warranty: 2 years parts & labor; 3 years with product registration

HVC305 120 V Specifications: 120 V~, 60 HZ, 5 A

HVC305-CE 220 V Specifications: 220-240 V~, 50-60 HZ, 400 W

RoHS COMPLIANT

Global Care

Ship Weight: 190 lbs/86 kg

Warranty: 2 years parts & labor; 3 years with product registration

HVC406 120 V Specifications: 120 V~, 60 HZ, 10 A

HVC406-CE 220 V Specifications: 220-240 V~, 50-60 HZ, 1050 W

RoHS COMPLIANT

Express Care U.S. ONLY

Ship Weight: 4 lbs/1.8 kg

Warranty: 1 year parts & labor

120 V Specifications: HSV1000 120 V~, 60 HZ, 1200 W

230 V Specifications: HSV1000-CE HSV1000-UK HSV1000-CN 220-240 V~, 50-60 HZ, 1200 W

RoHS COMPLIANT



PrimaVac™	Width IN/MM	Length IN/MM	Mil/Microns	Count per Case
In-Chamber 3 MIL	3 mil is the standard thickness for storing, freezing, or boiling food in individual servings or large quantities.			
HVCP30610	6 / 152	10 / 254	3 MIL / 75 µm	1000
HVCP30812	8 / 203	12 / 305	3 MIL / 75 µm	1000
HVCP31013	10 / 254	13 / 330	3 MIL / 75 µm	1000
HVCP31015	10 / 254	15 / 381	3 MIL / 75 µm	1000
HVCP31214	12 / 305	14 / 335	3 MIL / 75 µm	1000
HVCP31216	12 / 305	16 / 406	3 MIL / 75 µm	500
HVCP31620	16 / 406	20 / 508	3 MIL / 75 µm	250
In-Chamber 4 MIL	4 mil provides extra protection against tears from bones or sharp contents.			
HVCP40610	6 / 152	10 / 254	4 MIL / 100 µm	1000
HVCP41013	10 / 254	13 / 330	4 MIL / 100 µm	1000
HVCP41214	12 / 305	14 / 335	4 MIL / 100 µm	1000
In-Chamber Retherm	Retherm pouches are available in 3 or 4 mil. and feature reinforced corners that help the bags withstand exposure to heat.			
HVCPR30812	8 / 203	12 / 305	3 MIL / 75 µm	1000
HVCPR31015	10 / 254	15 / 381	3 MIL / 75 µm	1000
HVCPR41216	12 / 305	16 / 406	4 MIL / 100 µm	500

25095



Panini Grill

- Serve perfect panini, burgers and more up to 3" thick** – Hot off the grill
- Rear lid support** – Helps prevent messy drips
- Easy-grip handle** – With endurance hinge for longer life
- Built-in dampener** – With adjustable hinge tension
- Removable, easy-to-clean plates** – Remove with the push of a button
- Removable drip tray**
- Simplified cooking** – With easy-turn temperature dial and illuminated on/off switch
- Suction-pad legs** – Prevent slipping

Ship Weight: 19.6 lbs/8.9 kg
Warranty: 1 year parts & labor

120 V Specifications:
 25095
 120 V~, 60 HZ, 1800 W



26700

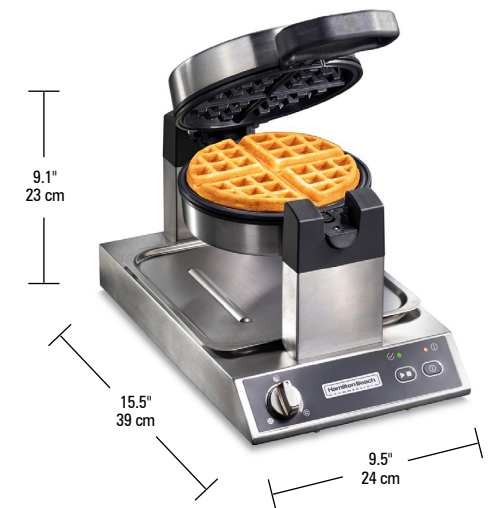

Belgian Waffle Maker

- 180° rotary feature with ergonomic handle** – For even baking and browning
- Durable construction** – With stainless steel housing and high-endurance hinge
- Simplified cooking** – Easy-turn dial with adjustable browning, auto shutoff & audible beep
- Easily removable, PFAS-free ceramic nonstick plates** – Instantly release with the press of a button without tools and are dishwasher safe
- Removable drip tray** – Catches excess batter & crumbs and is dishwasher safe
- Indicator lights** – Show you when power is on and waffle plates are preheated

Ship Weight: 14.4 lbs/6.5 kg
Warranty: 1 years parts & labor

120 V Specifications:
 26700
 120 V~, 60 HZ, 1300 W



Accessories and Parts

Bar Blenders

6126-908RR

HBB908R series 44 oz./1.3 L polycarbonate container



6126-908S

HBB908R series 32 oz./0.95 L stainless steel container



6126-255S (120 V)

Rio and HBF510 32 oz./0.95 L stainless steel container assembly for HBB255S and HBF510 series



6126-255S-CE (230 V)

Rio and HBF510 32 oz./0.95 L stainless steel container assembly for HBB255S and HBF510 series



BW800SS

Stainless steel 8 quart/8 L bowl with handles for CPM800 series stand mixer



990291700

Cutter assembly for HCO500 can opener



High-Performance Blenders

6126-650R

Fury, Tempest, and Summit 64 oz./1.8 L BPA-free copolyester container assembly for HBH550R, HBH650R and HBH850 series blenders



6126-851

48 oz./1.4 L AirWhip frothing jar for Summit Edge (HBH855 series blenders)



98455

Rio, Tango and HBF510 blender repair kit. Cutter assembly, clutch and gasket for HBB255, HBH455 and HBF510 series



6126-455 (120 V)

Rio, Tango, HBF510 48 oz./1.4 L BPA-free copolyester container assembly for HBB255, HBH455 and HBF510 series blenders



6126-455-CE (230 V)

Rio, Tango, HBF510 48 oz./1.4 L BPA-free copolyester container assembly for HBB255-CE, HBH455-CE, HBF510-CE series blenders



Commercial Juicers

UTC960

Under-the-counter pulp bin for HJE960R otto juice extractor series



6126-750R

Eclipse 48 oz./1.4 L BPA-free copolyester container assembly for HBH750 series blenders



6126-751R

48 oz./1.4 L AirWhip frothing jar compatible with Eclipse. Can be used with jar pad JP750 for Fury, Tempest and Expedito 600 series



6126-755R

Eclipse 64 oz./2 L BPA-free copolyester container assembly for HBH755 series blenders



6126-855R

Summit Edge 48 oz./1.4 L BPA-free copolyester container assembly for HBH855 series blenders



Back-of-the-House Equipment

SB961

Stainless steel replacement strainer juice basket and blade for HJE960R otto juice extractor series



WW800SS

Stainless steel wire whisk for CPM800 series stand mixer



FB800SS

Stainless steel flat beater for CPM800 series stand mixer



DH800SS

Stainless steel flat beater for CPM800 series stand mixer



98650R

Tempest, Summit, Revolution & Eclipse blender repair kit with cutter assembly, clutch, gasket, and retainer nut for HBH650R series, HBH755R series, HBH850 series, HBF600R/HBF600S series, and HBS1400R



BT650

Tamper for Fury and Tempest and Expedito HBF600R series blenders



JP750

Alternate jar pad can be used on Fury HBH550R, Tempest HBH650R, Eclipse HBH755R, and Expedito HBF600R series



Accessories and Parts

Drink Mixers

Agitators

Adds mixing flexibility and functionality to HMD200R, HMD300R, HMD400R, HMD880 and HMD1000 series drink mixers

928



For gently mixing

929



For mix-ins and hard ice cream

930



For hard ice cream*

* Fits models 94950, HMD900, HMD880 and HMD1000

** Fits models HMD880 and HMD1000

96000

Hands free activation for HMD880 MixStation™



96550

Hands free activation for HMD1000 MixStation™



110E

Universal 32 oz./95 L stainless steel container for all drink mixers by Hamilton Beach Commercial



BigRig™

HMIS12

12"/305mm shaft for BigRig™



HMIS14

14"/355mm shaft for BigRig™



HMIS16

16"/406mm shaft for BigRig™



HMIS18

18"/457mm shaft for BigRig™



HMIS21

21"/533mm shaft for BigRig™



HMI02W

19.5" whisk for BigRig™



Culinary Blenders (Containers)

990156300 (120 V)
990156400 (230 V)

Replacement motor kit for HMD200R and HMD400R series drink mixers



6126-510S-CE

64 oz/1.8 L stainless steel jar for HBF510, HBF510S and HBH455 series blenders



6126-HBF600S

Expeditor 64 oz./1.8 L stainless steel container assembly for HBF600S/HBF600SR series blenders



6126-1100SR

Expeditor 1 gallon/4 L stainless steel container assembly for HBF900S/HBF900SR and HBF1100S/HBF1100SR series blenders



Vacuum Packaging

SB254

Seal bar assembly for HVC254 series chamber machine

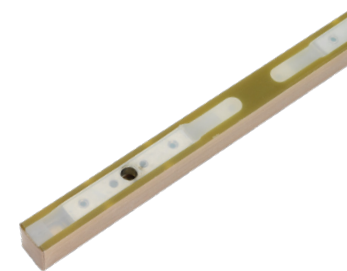

SB305

Seal bar assembly for HVC305 series chamber machine

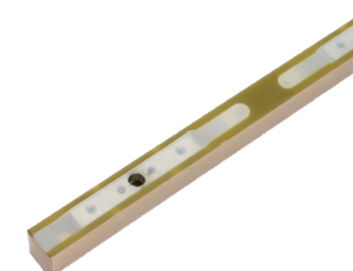

SB406

Seal bar assembly for HVC406 series chamber machine

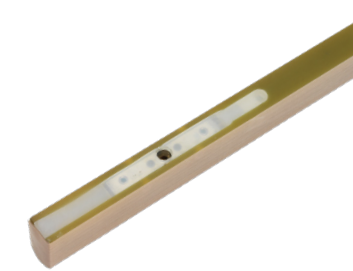

Culinary Blenders (Kits)

6126-HBF600R

Expeditor 64 oz./1.8 L BPA-free copolyester container assembly for HBF600/HBF600R series blenders



98400

Expeditor food blender repair kit with cutter assembly, clutch, gasket, and retainer nut for HBF500S series



98500

Expeditor food blender repair kit with cutter assembly, clutch, gasket, and retainer nut for HBF500



990415100

Expeditor cutter assembly, clutch, gasket, and retainer nut for HBF900S/HBF900SR and HBF1100S/HBF1100SR series



FP254

Filler plate for HVC254 series chamber machine



FP305

Filler plate for HVC305 series chamber machine



FP406

Filler plate for HVC406 series chamber machine



Global Warranty Coverage

Hamilton Beach Commercial® stands behind its products, and our global warranty coverage and customer service are second to none. If you ever have an issue, we provide fast, friendly service that's available when you need it.

FOR OUR U.S. CUSTOMERS:



For qualifying products, follow this easy 3 step process:

1. Dial 1-866-285-1087 to speak to a member of our highly trained technical services staff (M-F 8am-5pm EST). We will make an initial phone diagnosis.
2. If it is determined that minimal on-site maintenance cannot be performed, Hamilton Beach Commercial® will ship a replacement product to your location.
3. Once the replacement unit is received, you send the troubled unit back to Hamilton Beach Commercial® (we will provide the box and supporting materials to return the unit and we pay the freight cost for the returned unit).

For all other products, please call 1-866-285-1087 to receive assistance on your parts and labor warranty.

Note: Limitations and exclusions apply. Express Care is only available to end users located in the continental US, Alaska and Hawaii.

FOR OUR GLOBAL CUSTOMERS:



We have a network of highly trained service companies in over 60 countries worldwide.

We provide 24/7/365 support via our dedicated technical services website which includes:

- detailed troubleshooting and repair instructions
- drawings with exploded view
- recommended parts lists
- registered service centers by country
- operation manuals and agency certifications

Our technical services team, based in North Carolina USA, offers a variety of training options, including web-based training. Visit us at: hamiltonbeachcommercial.com to find your country service provider, contact us directly at +1-910-693-4277 or send an email to: commercial.support@hamiltonbeach.com.

Hamilton Beach
COMMERCIAL

hamiltonbeachcommercial.com

Hamilton Beach Commercial, 4421 Waterfront Drive, Glen Allen, Virginia 23060

©2026 Hamilton Beach Brands, Inc.